

Name: \_\_\_\_\_ ( )

Class: Primary 6 \_\_\_\_\_

## CHIJ ST NICHOLAS GIRLS' SCHOOL

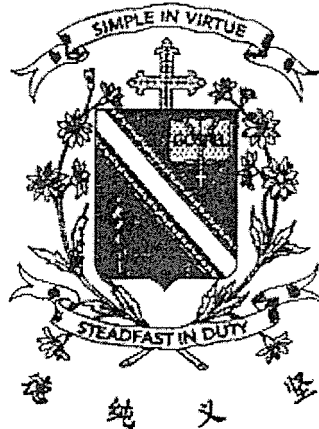

**Primary 6**

**Mid-Year Assessment**

**SCIENCE**

**BOOKLET A**

**11 May 2021**

**Total Time for Booklets A and B: 1 hour 45 minutes**

**28 questions  
56 marks**

**Do not open this booklet until you are told to do so.  
Follow all instructions carefully.  
Answer all questions.**

**This booklet consists of 18 printed pages.**

**Section A (28 x 2 marks = 56 marks)**

For each question from 1 to 28, four options are given. One of them is the correct answer. Make your choice (1, 2, 3 or 4). Shade the correct oval (1, 2, 3 or 4) on the Optical Answer Sheet provided.

1. Study the chart below:

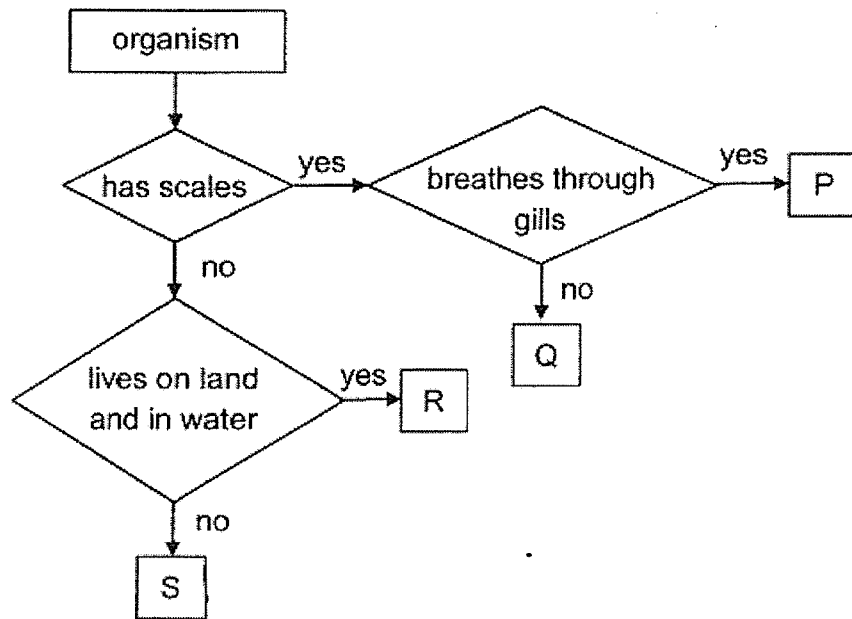

Which of the following letters P, Q, R or S best represents a frog and a crocodile?

	<b>Frog</b>	<b>Crocodile</b>
(1)	S	R
(2)	S	P
(3)	R	S
(4)	R	Q

2. The graph below shows the changes in the mass of different parts of a young plant during germination as it develops to become an adult plant.

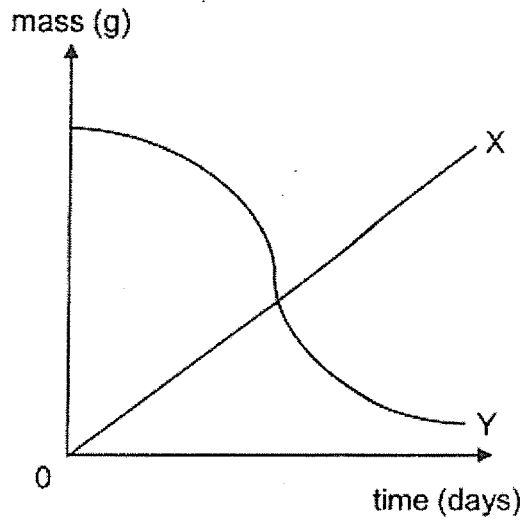

Which of the following plant parts best represent graphs X and Y?

	X	Y
(1)	seed leaves	young plant
(2)	young plant	seed leaves
(3)	seed coat	roots
(4)	roots	young plant

3. The characteristics of two organisms are shown below.

Characteristics	Organisms	
	P	Q
Makes its own food	yes	no
Reproduce by seeds	yes	no

Which of the following best represents organisms P and Q?

	P	Q
(1)	flowering plant	mushroom
(2)	flowering plant	fern
(3)	fern	flowering plant
(4)	fern	mushroom

4. Some people were trapped in a small lift and some adults started banging on the door and a child started crying. The graph below shows the changes in the volume of three gases X, Y and Z in the lift as time passes.

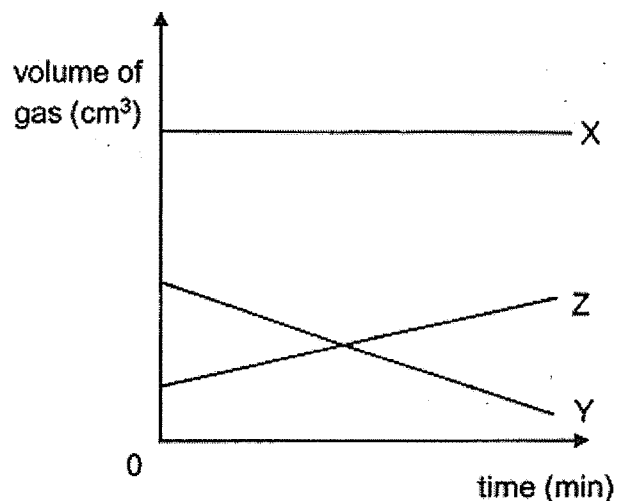

Which of the following best represents gases X, Y and Z?

	X	Y	Z
(1)	nitrogen	carbon dioxide	oxygen
(2)	nitrogen	oxygen	carbon dioxide
(3)	oxygen	carbon dioxide	nitrogen
(4)	carbon dioxide	nitrogen	oxygen

5. Four pots W, X, Y and Z were set up to investigate the conditions that affect germination. The conditions for each pot are shown in the table below. A tick (✓) shows that the condition is present.

Pot	Conditions			
	Water	Light	Number of seeds	Oxygen
W	✓		10	✓
X	✓	✓	5	
Y	✓	✓	5	✓
Z			10	✓

Which of the following could be possible aims of the above set-ups?

- A To find out if light is needed for germination.
- B To find out if water is needed for germination.
- C To find out if oxygen is needed for germination.
- D To find out if the number of seeds affect germination.

- (1) A and B only
- (2) A and D only
- (3) B and C only
- (4) C and D only

6. The diagram below shows the cross-section of a flower.

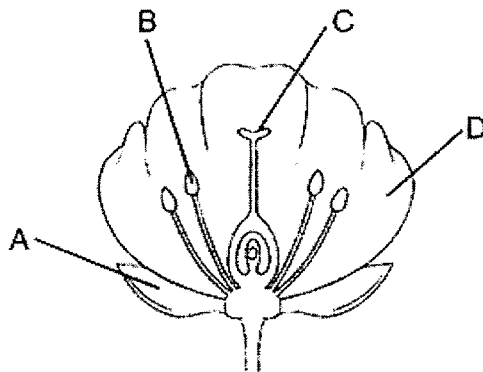

One part of the flower was removed and the flower did not develop into a fruit.

Which part of the flower A, B, C or D was removed?

- (1) A
- (2) B
- (3) C
- (4) D

7. The diagram below shows cells P and Q during process H in the reproduction of humans.

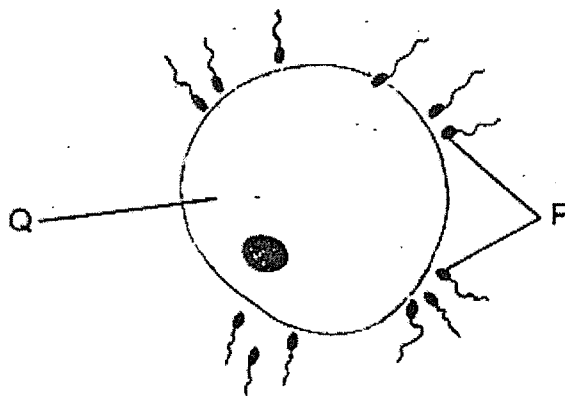

Which of the following statements are true?

- A Process H is always successful.
  - B More than one cell P can enter cell Q.
  - C Cell P is produced in the male reproduction system.
  - D Process H occurs in the female reproductive system.
- (1) A and B only  
(2) A and D only  
(3) B and C only  
(4) C and D only
8. After harvesting their crops, farmers may leave behind some dead plants in the fields. How does leaving behind these dead plants benefit the farmers?
- (1) To allow new plants to grow.
  - (2) To provide food for the animals in the soil.
  - (3) To provide a new habitat for animals in the fields.
  - (4) To make the soil fertile when the dead plants decompose.

9. Alvin carried out an experiment to study the preferred environment of worms. Twenty worms were put in the middle of dish A. After ten minutes, the number of worms in each section of dish A was counted.

The experiment was repeated with dishes B and C using the same number of similar worms.

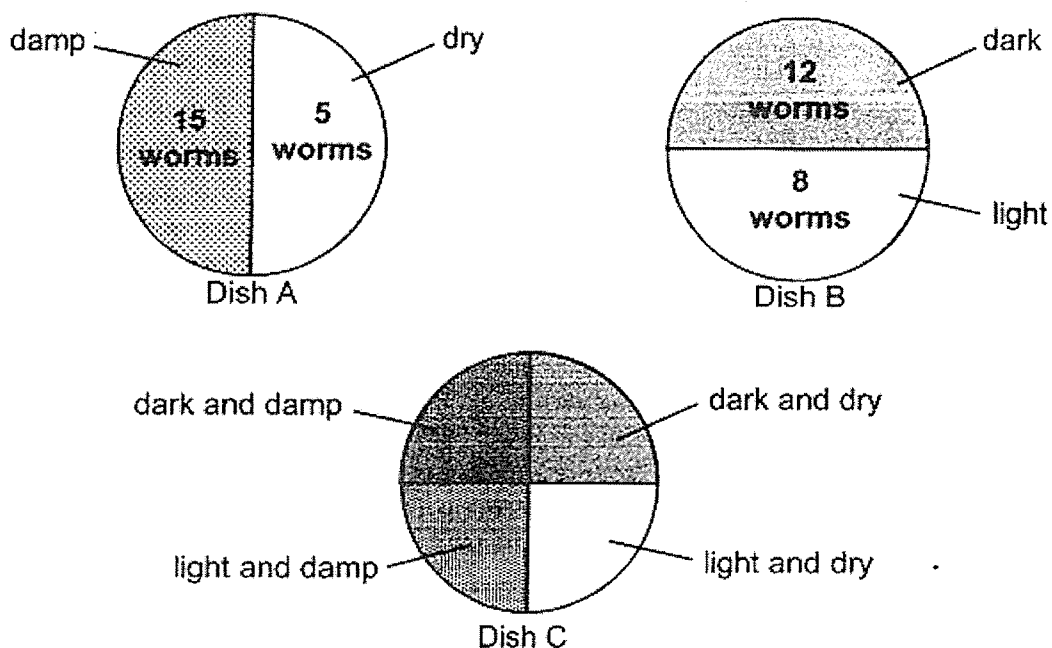

Which of the following shows the likely number of worms in each section in dish C?

(1)

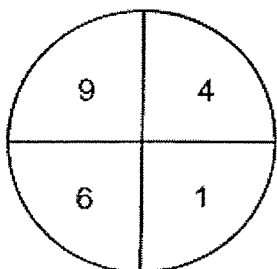

(2)

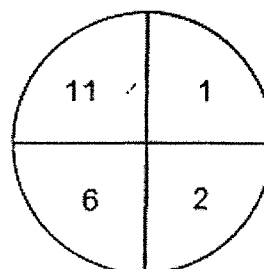

(3)

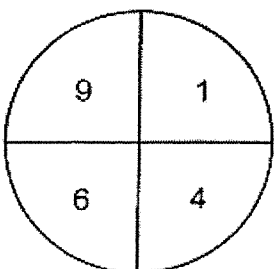

(4)

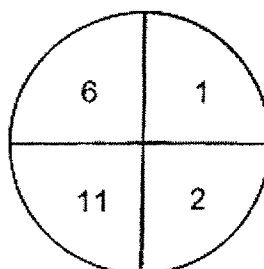

10. Study the food web below.

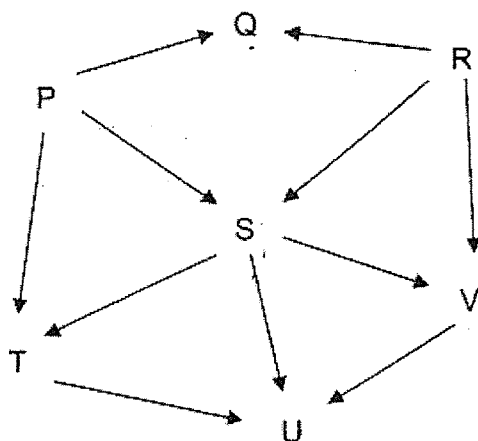

Which of the following statements are true of the organisms in the food web?

- A S and Q are herbivores.
- B T and U are carnivores.
- C P and R are food producers.
- D S and V are both prey and predators.

- (1) A and C only
- (2) B and D only
- (3) A, C and D only
- (4) B, C and D only



11. Xiaoling wanted to conduct an experiment on photosynthesis. She set up her experiment in the garden as shown in the diagram below.

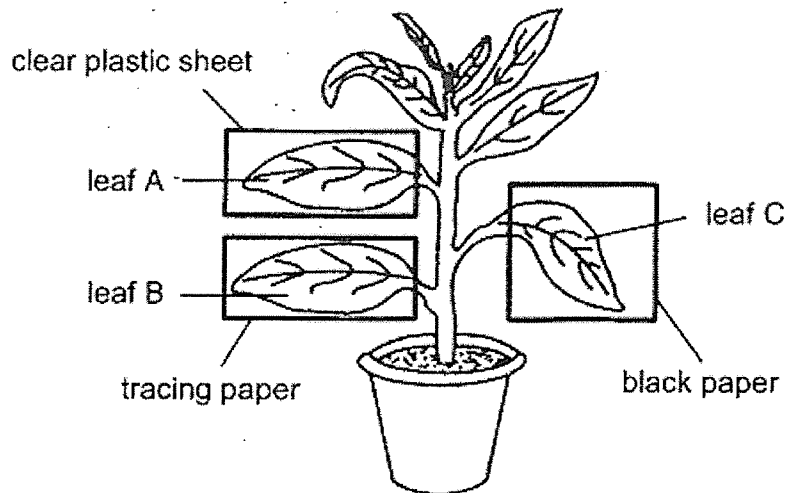

After a few hours, Xiaoling removed the leaves and conducted a starch test on the leaves. She found out that leaf A contained the most amount of starch as compared to leaves B and C.

What can she conclude from the above experiment?

- (1) Light can affect the production of starch.
- (2) Light can pass through different types of materials.
- (3) The amount of light affects the rate of photosynthesis.
- (4) The presence of starch shows that photosynthesis has occurred.

12. Xiao Ming placed three solids made of materials L, M and N into a container of water. He made some observations as shown below.

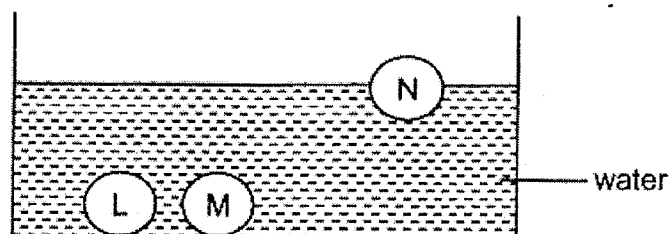

He made three statements:

- A L and M have the same mass.
- B L and M are made of the same material.
- C M and N are made of different materials.

Which statement(s) can be concluded from his observation?

- (1) C only
  - (2) A and B only
  - (3) B and C only
  - (4) None of the above statements
13. The table below shows some properties of four materials A, B, C and D.

Materials	Property		
	Transparent	Good conductor of heat	Magnetic material
A	x	✓	x
B	✓	x	✓
C	✓	x	x
D	x	✓	✓

Key
✓ : yes
x : no

Which material A, B, C or D best represents copper?

- (1) A
- (2) B
- (3) C
- (4) D

14. Which of the following statements are true for all magnets?

- (1) A magnet loses its magnetism once it is broken into two.
- (2) The larger the size of a magnet, the stronger its magnetism.
- (3) When two metal bars attract each other, they are definitely magnets.
- (4) A magnet with a greater magnetism can attract an iron pin from a further distance.

15. Abdullah carried out an experiment with a syringe containing substance X. The end of the syringe was sealed. He pulled the plunger of the syringe and it moved to the position as shown in diagram B.

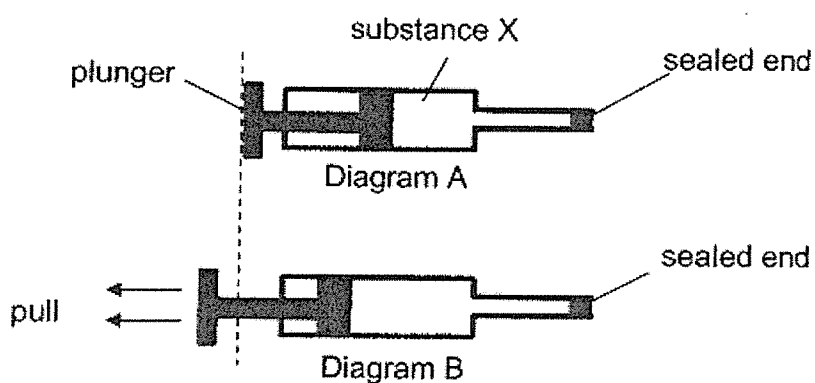

Based on his observation, what conclusion can he draw about substance X?

- (1) Substance X is a gas and it can be compressed.
- (2) Substance X is a solid as it cannot be compressed.
- (3) Substance X is a matter as it has mass and occupies space.
- (4) Substance X is a gas and it does not have a definite volume.

16. Which of the following are examples of matter?

- A air
- B light
- C shadow
- D water vapour
- E carbon dioxide

- (1) B and C only
- (2) A, D and E only
- (3) B, C, D and E only
- (4) A, C, D and E only

17. The diagram below shows part of the water cycle.

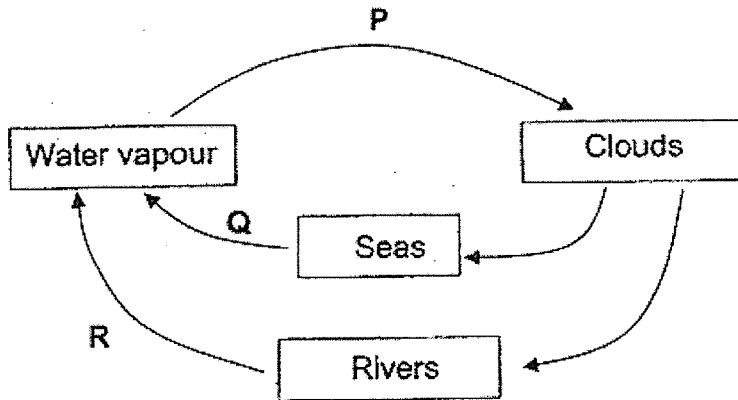

Which of the following is correct?

	Evaporation occurs at	Condensation occurs at	Heat loss occurs at
(1)	Q	R	Q and R
(2)	Q and P	R	R
(3)	R	P and Q	Q
(4)	Q and R	P	P

18. Look at the set up below. When a flask filled with tap water is lowered into a basin of hot water, it is observed that the water level in the glass tube falls slightly at first and then starts to rise steadily.

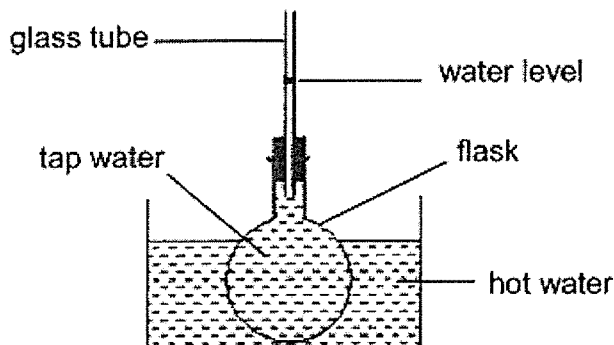

Why does the water level in the glass tube fall slightly when the flask is lowered into the basin of hot water?

- (1) The hot water loses heat to the tap water and contracts.
- (2) The flask expands before the tap water in the flask expands.
- (3) The tap water in the flask gains heat from the hot water and expands.
- (4) The tap water in the flask contracts slightly as the flask gains heat from the hot water.

19. A boy stood under a lamp as shown.

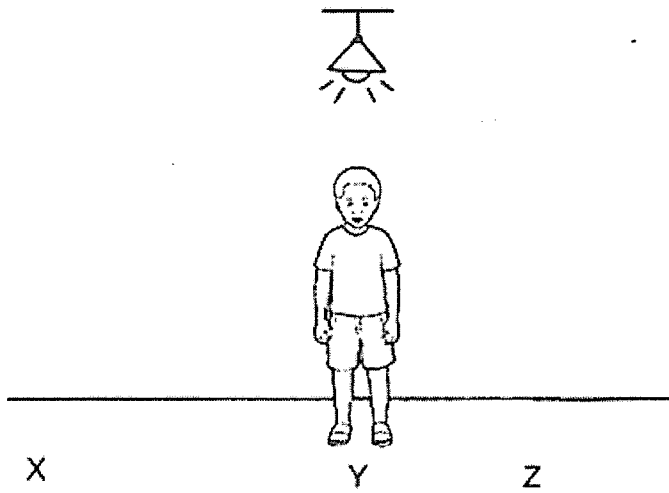

He walked from position Y to position Z and then to position X in a straight line. Which graph below shows the length of his shadow changed during this time?

(1)

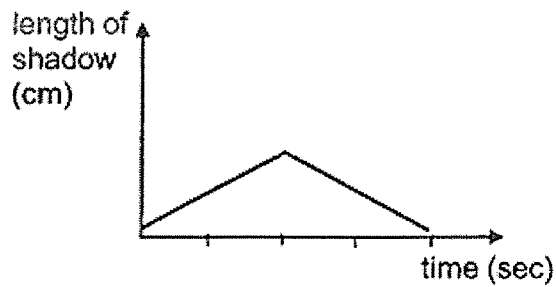

(2)

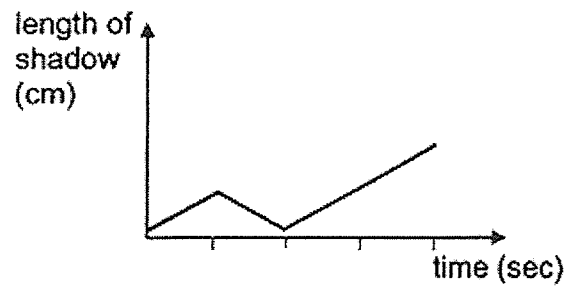

(3)

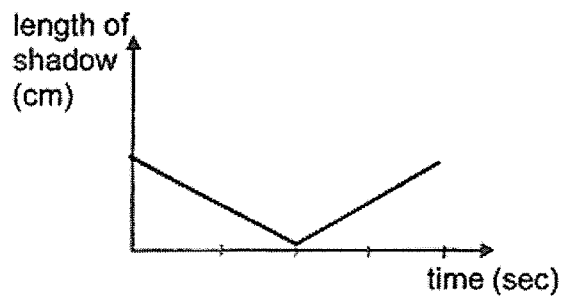

(4)

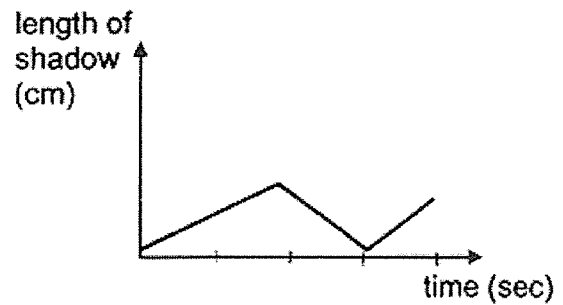

20. Two identical opaque cones are glued together at the base to form the structure below.



Which of the following shadows can most possibly be formed by the structure?



S



T



U

- (1) U only  
(2) S and T only  
(3) T and U only  
(4) S, T and U
21. Two copper balls X and Y, of different masses were put into a beaker of boiling water at the same time.

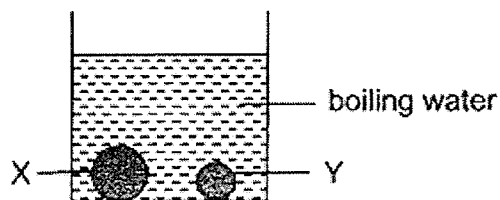

Which of the following statements about the copper balls are correct after five minutes?

- A X has more heat energy than Y.  
B X has a higher temperature than Y.  
C X and Y have the same temperature.  
D X and Y have the same amount of heat energy.
- (1) A and B only  
(2) A and C only  
(3) B and D only  
(4) C and D only

22. Three containers K, L and M were made of different materials. They were filled with equal amount of boiling water. The time taken for the water in each container to cool down was plotted on the graph as shown below.

Temperature ( $^{\circ}\text{C}$ )

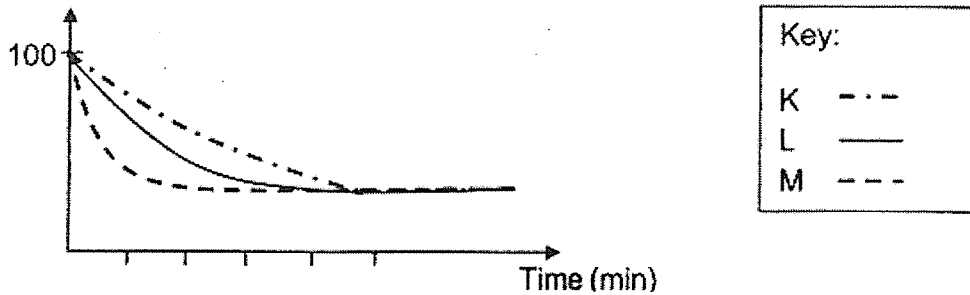

Based on the above graph, identify the possible material of each container.

	Container K	Container L	Container M
(1)	styrofoam	ceramic	aluminium
(2)	aluminium	ceramic	styrofoam
(3)	ceramic	styrofoam	aluminium
(4)	aluminium	styrofoam	ceramic

23. Identical batteries and bulbs are used to set up the two electrical circuits shown below.

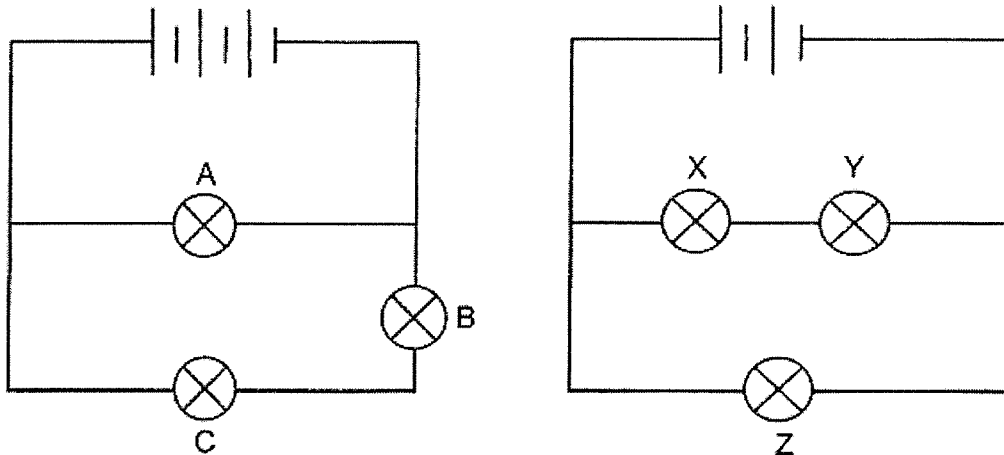

Which of the following correctly describes the brightness of the bulbs?

	Brightest bulb(s)	Dimmest bulb(s)
(1)	A	X, Y
(2)	A	Z
(3)	A, B, C	X, Y, Z
(4)	B, C	Z

24. Caleb wanted to find out whether four rods A, B, C and D were electrical conductors or insulators. He set up the electrical circuit as shown below.

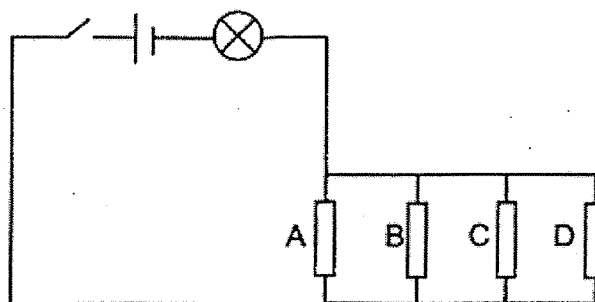

The table shows what happened when the switch was closed and certain rod(s) was/were removed.

Rod(s) removed from electrical circuit	Did the bulb light up?
B	yes
C and D	yes
A, B and C	no
B, C and D	no

Which of the following correctly concludes the experiment?

	A	B	C	D
(1)	conductor	insulator	conductor	insulator
(2)	insulator	conductor	conductor	insulator
(3)	conductor	insulator	insulator	conductor
(4)	insulator	conductor	insulator	conductor

25. The diagram below shows an electric circuit with a coil of nichrome wire and a switch.

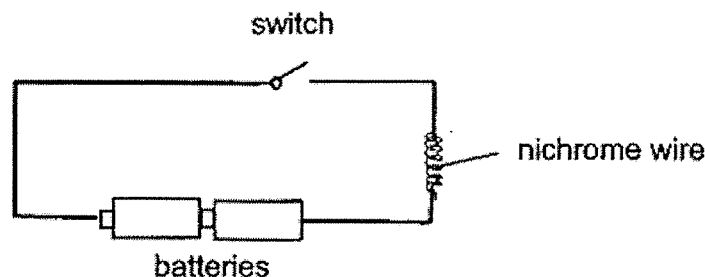

When the switch was closed, the nichrome wire turned hot and started to glow. Which one of the following shows the correct energy conversion?

- (1) Kinetic energy → Electrical energy → Heat energy → Light energy
- (2) Electrical energy → Potential energy → Heat energy → Light energy
- (3) Potential energy → Electrical energy → Heat energy → Light energy
- (4) Potential energy → Kinetic energy → Electrical energy → Heat energy



26. A spring is compressed and released at A. It moves to B as shown.

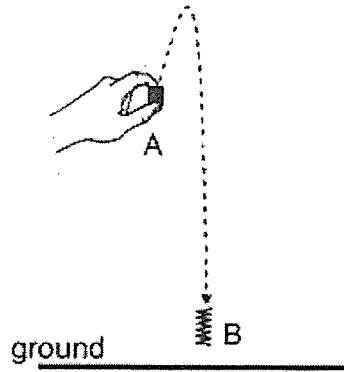

The graph shows the amount of different types of energy of the spring at B.

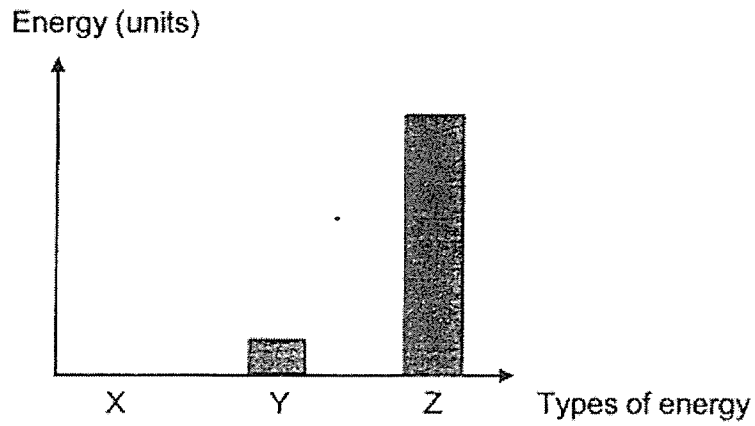

Which one of the following correctly represents the type of energy at B.

	X	Y	Z
(1)	Kinetic energy	Gravitational potential energy	Elastic potential energy
(2)	Elastic potential energy	Kinetic energy	Gravitational potential energy
(3)	Gravitational potential energy	Elastic potential energy	Kinetic energy
(4)	Elastic potential energy	Gravitational potential energy	Kinetic energy

27. A boy is riding on his pogo stick as shown.

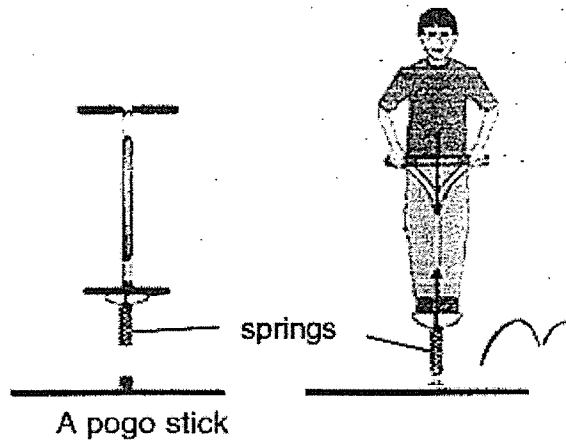

Which of the following forces enable the boy to move over a distance?

- A Magnetic force
- B Frictional force
- C Gravitational force
- D Elastic spring force

- (1) A and D only
- (2) C and D only
- (3) A, C and D only
- (4) B, C and D only

28. The following statements about forces are given by four pupils.

- Aziz A force is a push or a pull.
- Ben A force cannot be seen and felt.
- Dollah A force can change the shape of an object.
- Cathy A force cannot change the direction of a moving object.

Who made a correct statement?

- (1) Aziz and Ben only
- (2) Aziz and Dollah only
- (3) Ben, Cathy and Dollah only
- (4) Aziz, Cathy and Dollah only

~End of Booklet A~

Name : \_\_\_\_\_ (     )

Class : Primary 6 \_\_\_\_\_

## CHIJ ST NICHOLAS GIRLS' SCHOOL

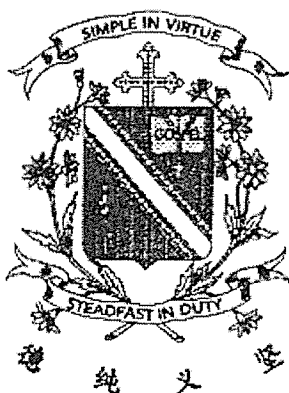

Primary 6

Mid-Year Assessment

SCIENCE

BOOKLET B

11 May 2021

Total Time for Booklets A and B: 1 hour 45 minutes

12 questions  
44 marks

Do not open this booklet until you are told to do so.  
Follow all instructions carefully.  
Answer all questions.

This paper consists of 13 printed pages.

Booklet A	56
Booklet B	44
Total	100

---

Parent's Signature/Date

**Section B (44 marks)**

For questions 29 to 40, write your answers in this booklet.

The number of marks available is shown in the brackets at the end of each question or part question.

29. Sally was taking part in an activity as shown in the diagram below.

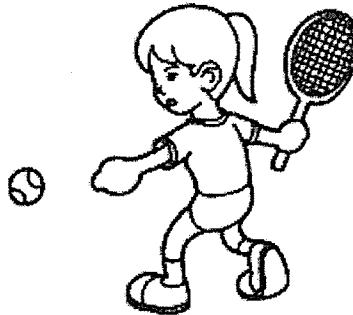

Her heart rate was measured and recorded in the graph below.

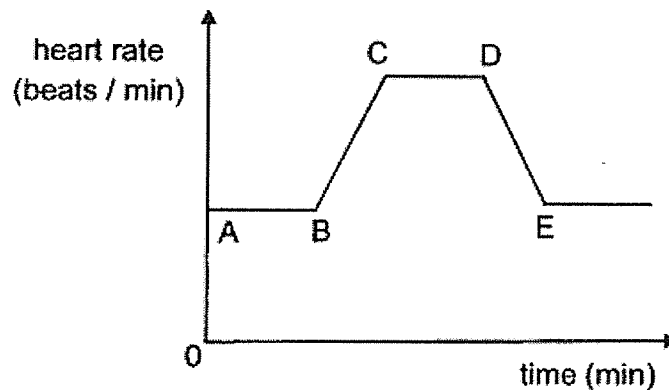

- (a) At which point A, B, C, D or E did she start taking part in the above activity? [1]

---

- (b) She observed that her heart rate increased during the activity. After 30 minutes, Sally stopped this activity and took a rest. While she was resting, she observed that her heart rate started to decrease. Explain this observation. [2]

---

---

---



30. The diagram below shows a bunch of berries. These berries contain seeds.

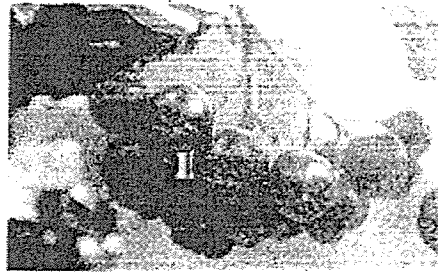

(a) Why do plants produce seeds? [1]

---

---

(b) Animals such as birds help to disperse the seeds in these berries. Describe how these birds help in the dispersal process. [2]

---

---

Shane wanted to find out if the colour of the berries affect the dispersal of their seeds. He hung different coloured beads on the same green plants and asked his friend to look for the beads for 5 minutes. The table below shows the results.

Colour of beads	Number of beads found
Black	11
Orange	9
Green	3
Red	18

(c) Which colour was the easiest to spot on the plants? [1]

---

(d) What can Shane do to make the results of his experiment more reliable? [1]

---

---



31. Nassim took water samples from different ponds P, Q, R and S. A coin was placed at the bottom of a container and water taken from pond P was poured until the coin could no longer be seen as shown in the set-up below. The height  $h$  of the water was recorded.

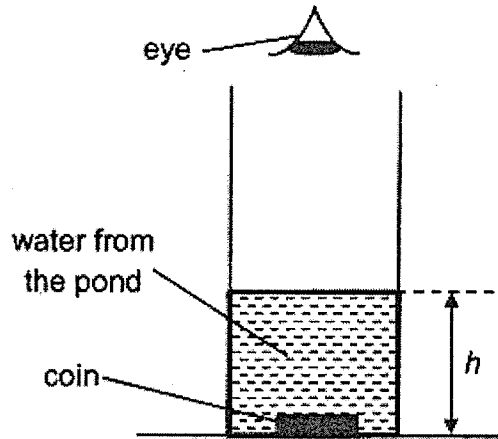

The experiment was repeated with water taken from ponds Q, R and S. The results are shown in the table below.

Pond	$h$ (cm)
P	15
Q	5
R	30
S	18

- (a) At which pond P, Q, R or S would there be the least number of plants growing in it? Explain your answer. [2]

---



---



---



Nassim recorded the number of organisms found at pond R as shown in the table below.

Organisms	Number of organism
butterfly	2
caterpillar	3
catfish	2
frog	2
tadpole	3
water hyacinth	4
water lily	2

- (b) He concluded that there are five populations of consumers. Do you agree? Explain your answer. [2]

---



---



---

32. The table below shows cells A, B and C and their cell parts. A tick (✓) shows that the cell part is present.

Cell	Cell wall	Cell membrane	Chloroplast
A		✓	
B	✓	✓	✓
C	✓	✓	

- Based on the table above, which cell A, B or C is a root-hair cell? Give two reasons to support your choice. [2]

Cell: \_\_\_\_\_

Reason 1: \_\_\_\_\_

\_\_\_\_\_

Reason 2: \_\_\_\_\_

\_\_\_\_\_



33. Samy conducted an experiment to study the food relationships between animals X, Y and W. Animal W feeds on leaves only.

At the start, Samy placed some animals W and X in a tank with some leaves. He counted the number of animals at the end of each week. After two weeks, he added animals Y.

His results are shown below.

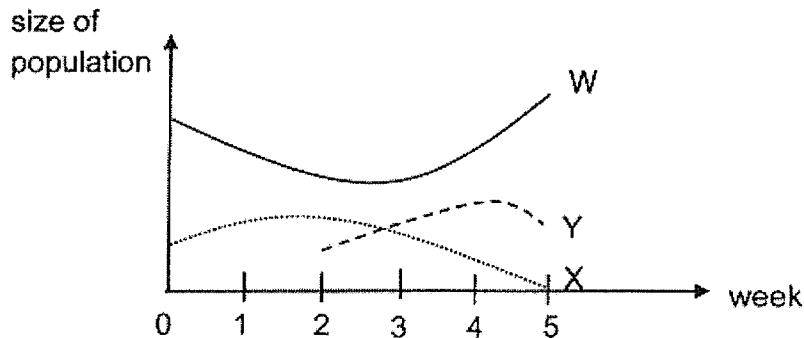

- (a) What is the food relationship between animals W and X? [1]

---

- (b) The population of animal Y decreased towards the end of week 4. Explain why. [2]

---

---

- (c) What is a food chain? [1]

---





34. Davi conducted an experiment with the set up below. She switched on the lamp and observed that the water level X in the glass tube moved down after some time. The plunger remained at the same place.

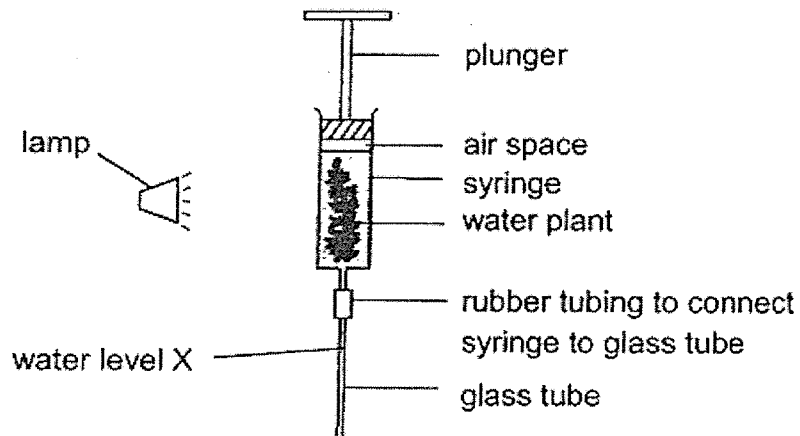

- (a) Explain why the water level at X moved down the glass tube after some time. [2]

---

---

---

- (b) When the lamp was moved nearer to the syringe, would the water level in the glass tube moved down faster, slower or at the same rate as before? [1]

---

- (c) Explain your answer in (b). [1]

---

---



35. An electrical system for a fan and an air conditioner is shown below. The system prevents both the fan and the air conditioner from being turned on at the same time. W is an iron bar placed inside a coil of wire. P and Q are two iron pins in contact with each other. Pin P is fixed. Pin Q is attached to a metal rod and can rotate about point X.

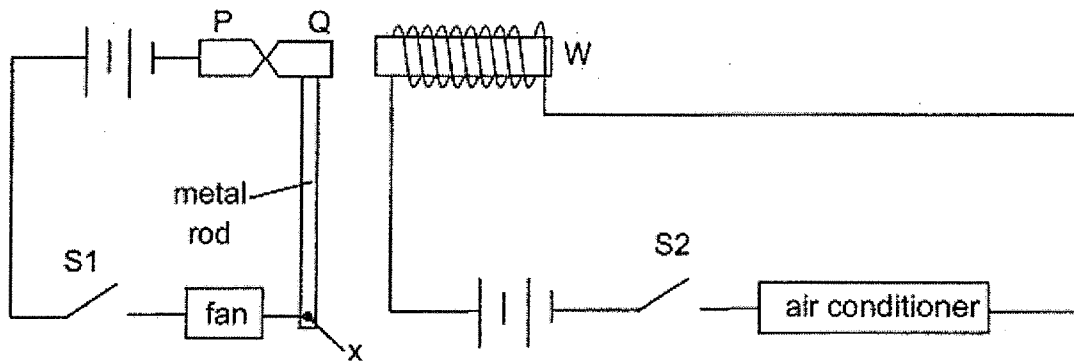

When switch S1 was closed, the fan turned on.

- (a) What would happen to pin Q when switch S2 was closed? Explain your answer. [1]

---



---

- (b) Give a reason why the fan was turned off when switch S2 was closed. [1]

---

- (c) Q was replaced with a pin made of another material. The fan was switched on when switch S1 was closed but the fan did not turn off when switch S2 was closed. Suggest a material of Q. Explain your answer. [2]

---



---



---



36. Kai Xin poured the same amount of water on two identical towels X and Y and hung them out to dry in the same place as shown below.

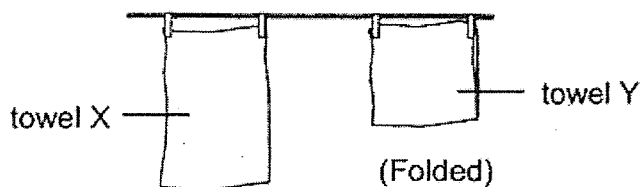

- (a) A few hours later, he found that towel X dry faster than towel Y. Explain why. [2]

---

---

- (b) State two other factors that would cause the towels to dry faster. [1]

(i) \_\_\_\_\_

(ii) \_\_\_\_\_

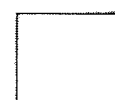

37. The diagram below shows a toy. When the string is pulled, it will cause the wheel to spin and fly off the handle.

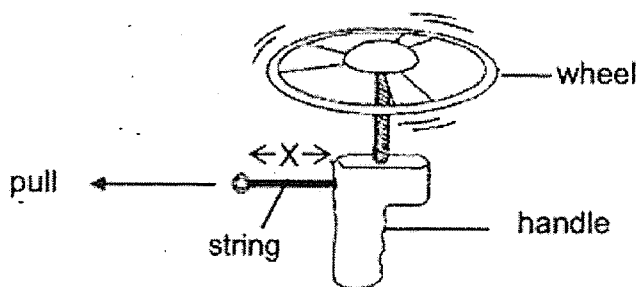

Jack wanted to find out how the number of spins of the wheel changes when the string is pulled to different lengths.

The table shows the results of his experiment.

Length of the string when pulled (cm)	Number of times the wheel spins
5	3
10	6
15	10

- (a) Jack used the same wheel throughout his experiment. What was the reason? [2]

---



---



---

- (b) What is the relationship between the length of the string when pulled and the number of times the wheel spins? [1]

---



---

- (c) State two forces that were exerted on the wheel as it spun in the air. [2]

(i) \_\_\_\_\_

(ii) \_\_\_\_\_



38. Shaun placed two identical containers A and B on a beam balance as shown in the diagram.

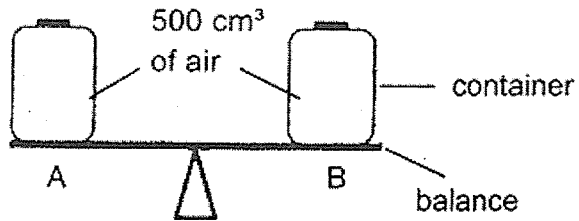

(a) What would he observe when he removed 200 cm<sup>3</sup> of air from container A? [1]

---

---

(b) What would be the volume of air in container A after he had removed 200 cm<sup>3</sup> of air? Explain your answer. [2]

---

---

---



39. A bimetallic strip consists of two metals attached firmly to each other. In the bimetallic strip below, metal X expands at a faster rate than metal W when it is heated.

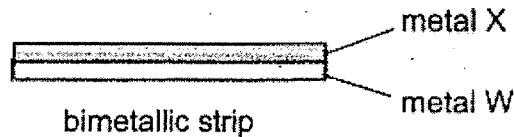

After heating, John observed that the strip bent as shown in the diagram below.

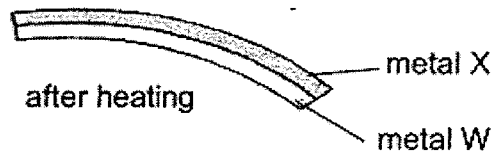

- (a) Give a reason why it bent as shown. [1]

---

John wanted to use the same type of bimetallic strip to construct a fire alarm system for his science project. His set-up is shown below.

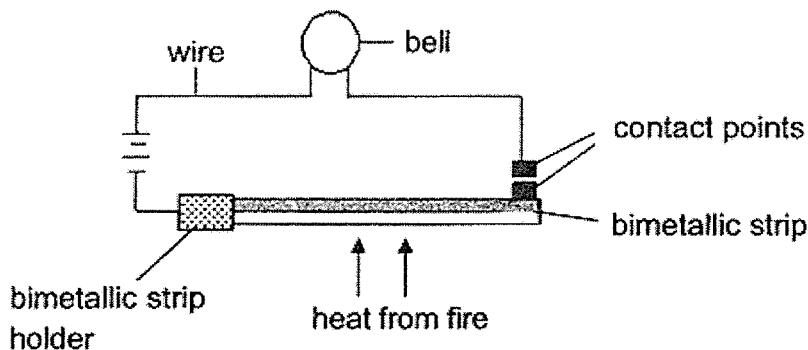

When the bimetallic strip gets heated up by the fire, it will bend. The two contact points will touch and the circuit will be closed. This will cause the bell to ring. However, when he tried out his set-up, the bell did not ring even though the bell was in working condition.

- (b) Explain why the bell did not ring. [2]

---



---

- (c) What is the most important property John must consider when he choose the material for making the contact points? [1]

---



40. Monica used 3 different types of materials, A, B and C to make the following cut-outs.

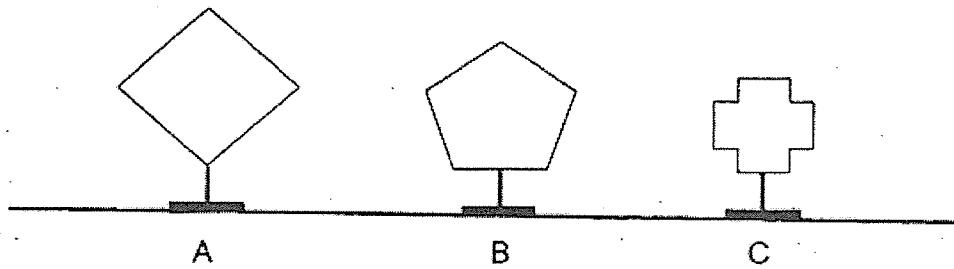

She then placed the cut-outs between a screen and a lighted torch as shown in the diagram below.

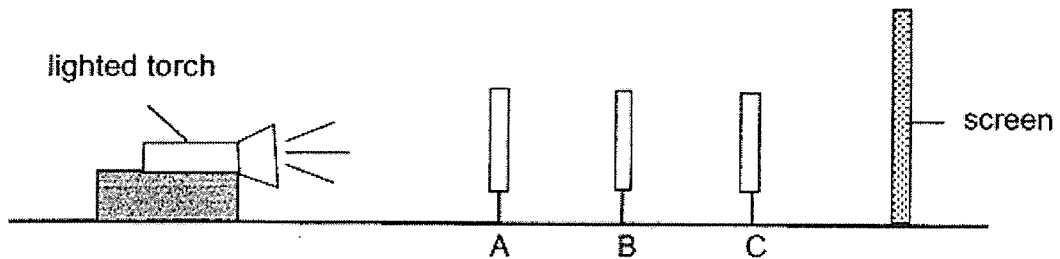

The diagram below shows the shadow which was cast on the screen.

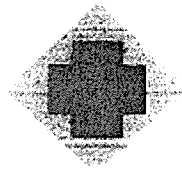

Legend	
	Dark shadow
	Light shadow

(a) State the property of the materials that A, B and C are made of to cast the shadow as seen above. [1]

(i) Material A : \_\_\_\_\_

(ii) Material B : \_\_\_\_\_

(iii) Material C : \_\_\_\_\_

(b) State one property of light that causes the formation of shadows. [1]

\_\_\_\_\_

\_\_\_\_\_

(c) If the torch is changed to one that gives out brighter light, how will it affect the size of the shadow formed? [1]

\_\_\_\_\_

~ End of paper ~

